

paper should be same colour on both sides

Ciervo (Dear) Román Díaz

①

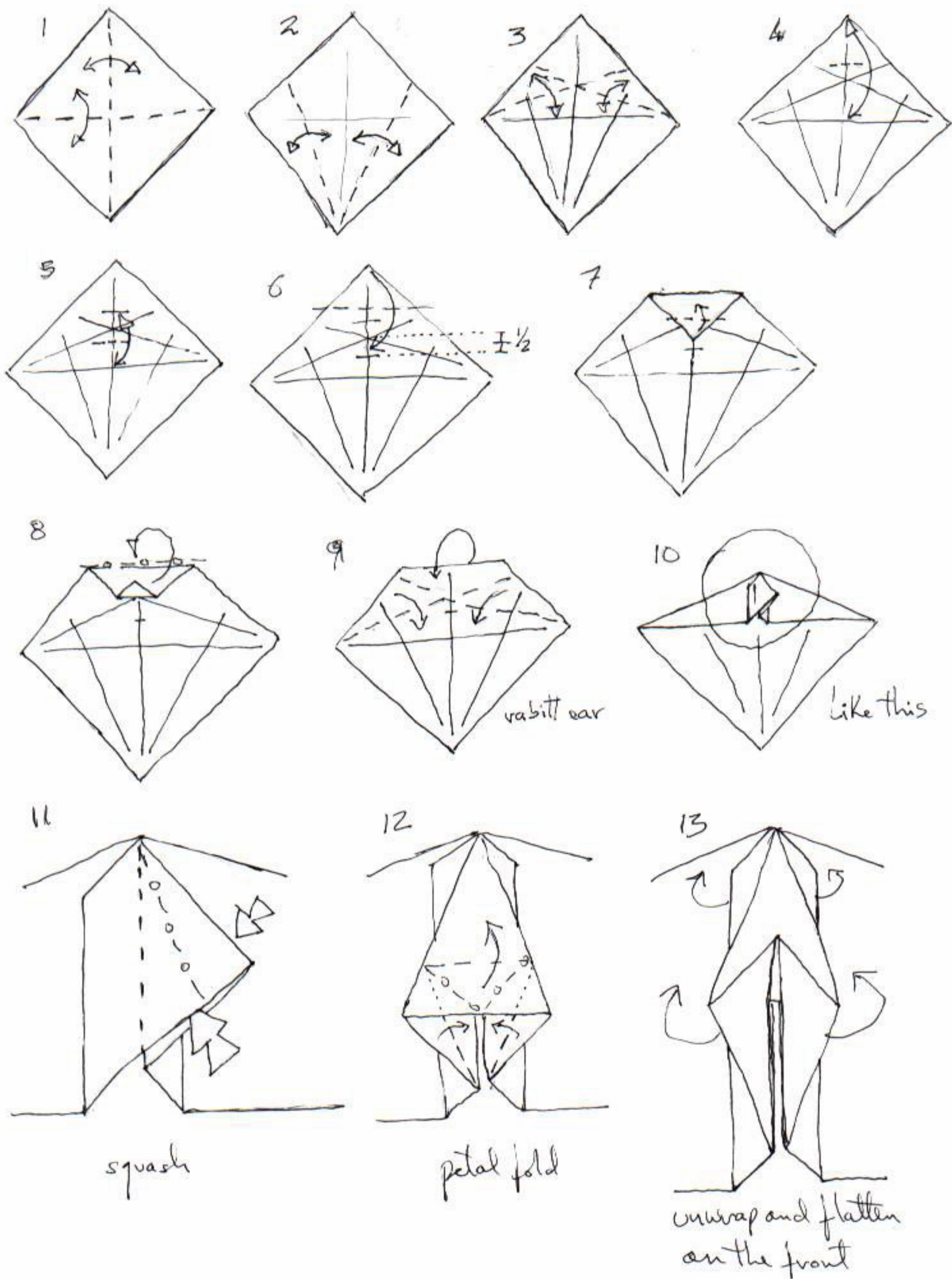

Ciervo

(2)

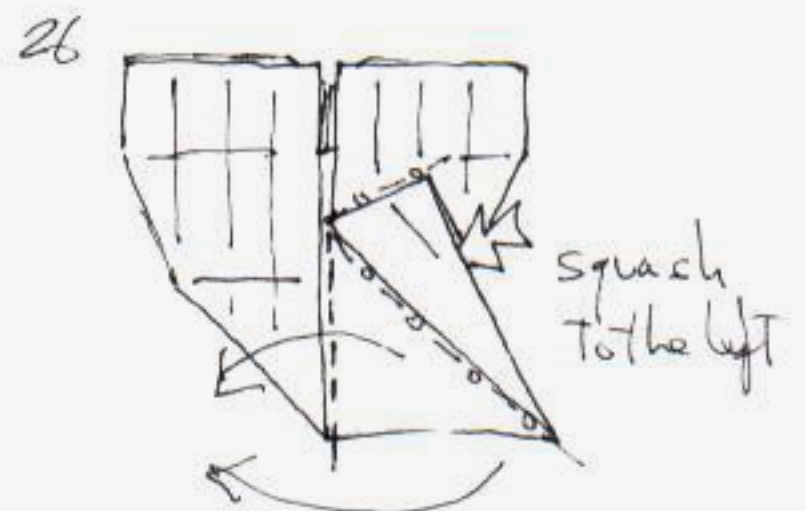
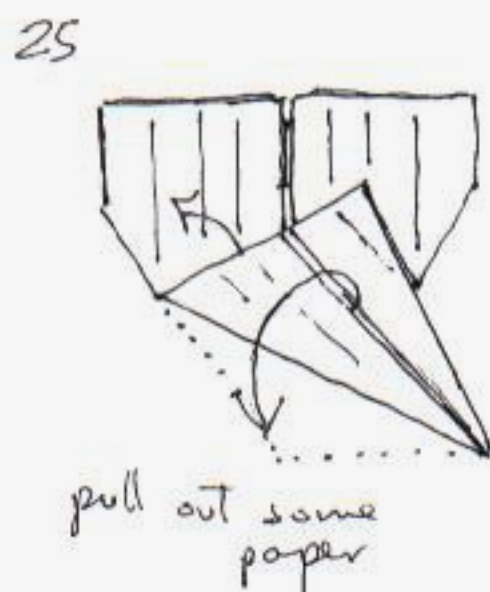
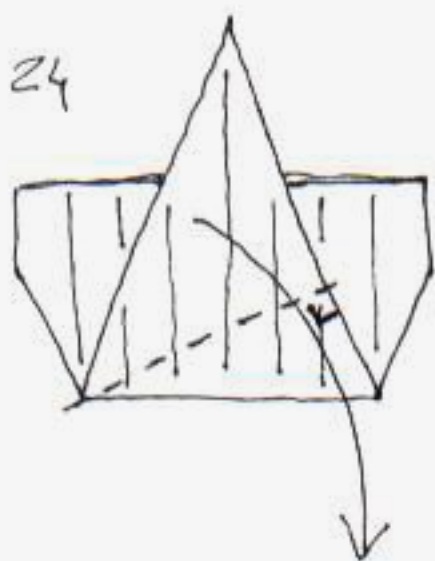
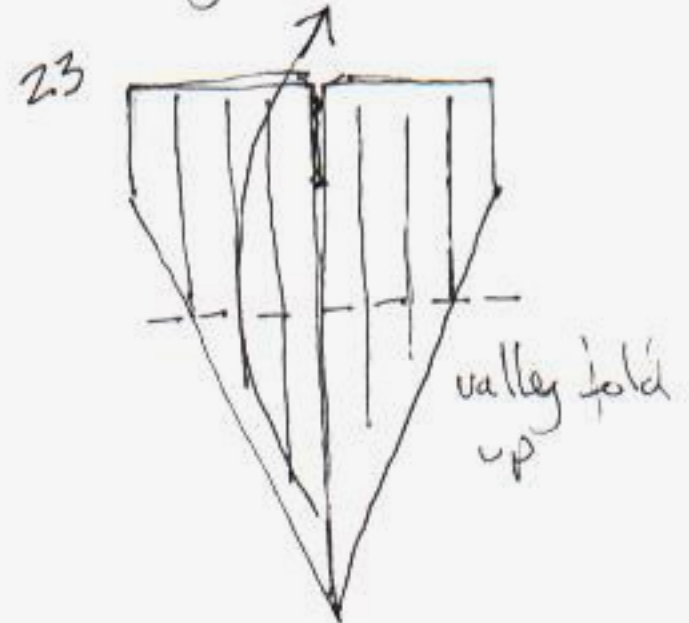
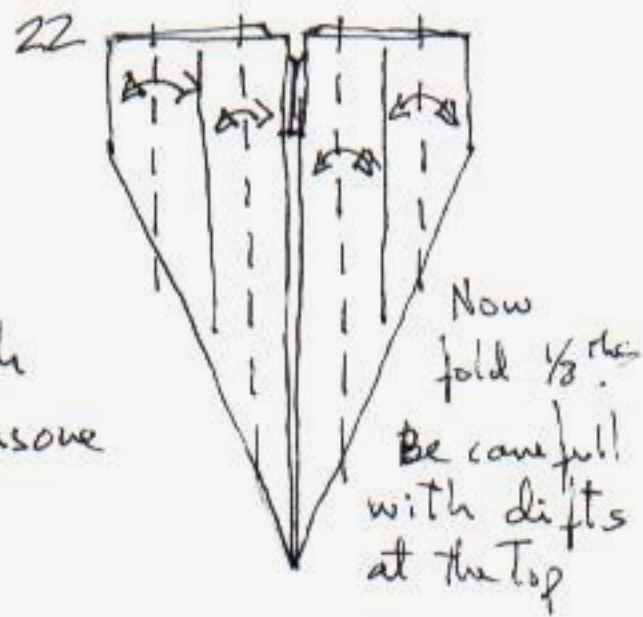
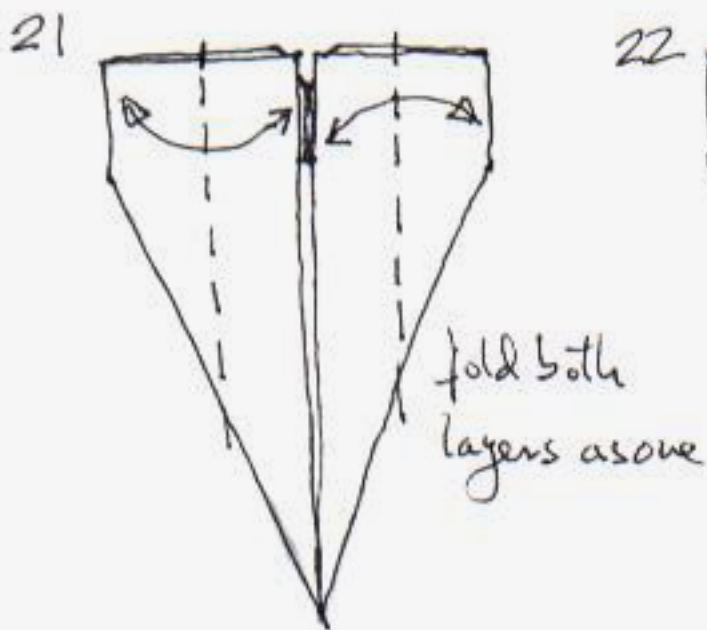
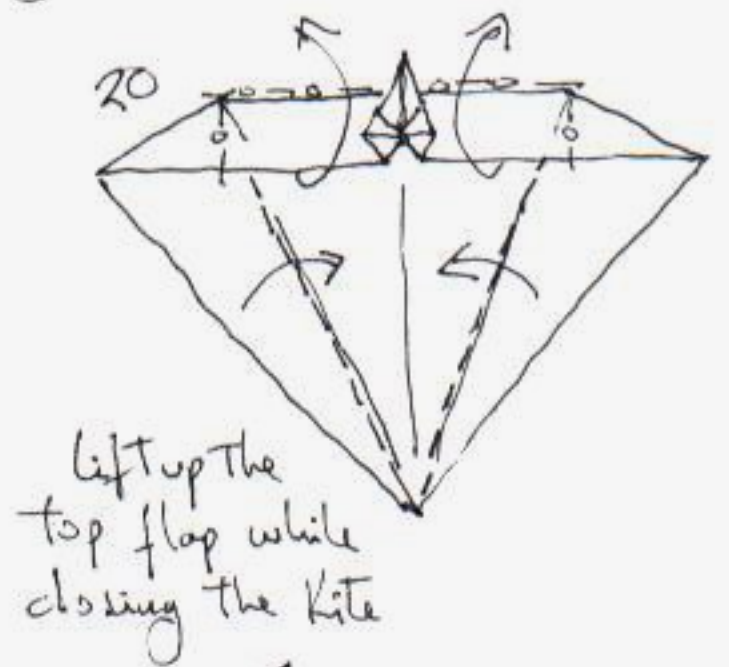
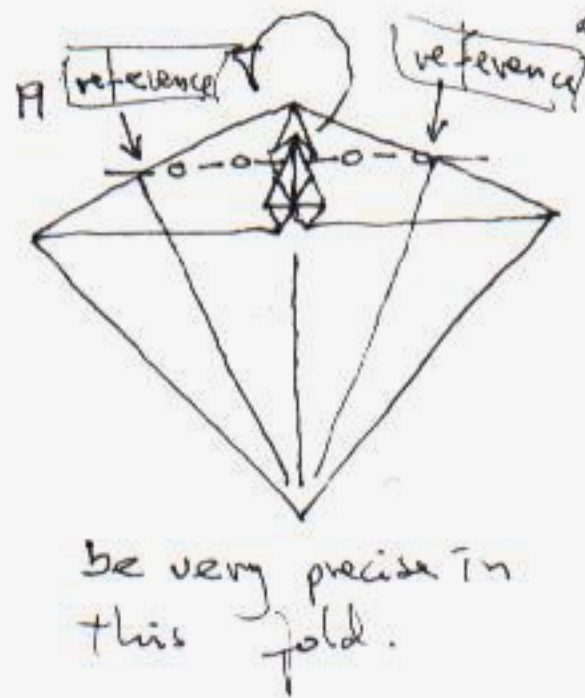
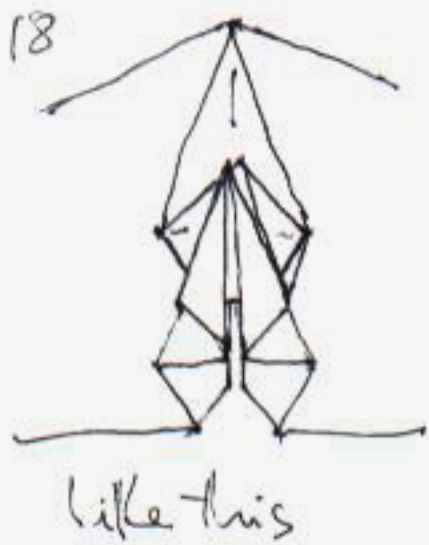
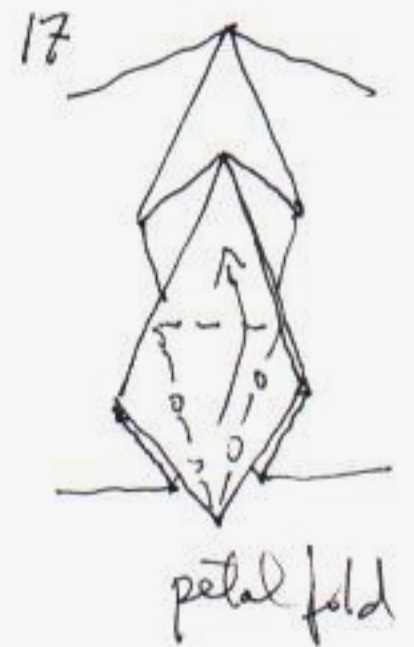
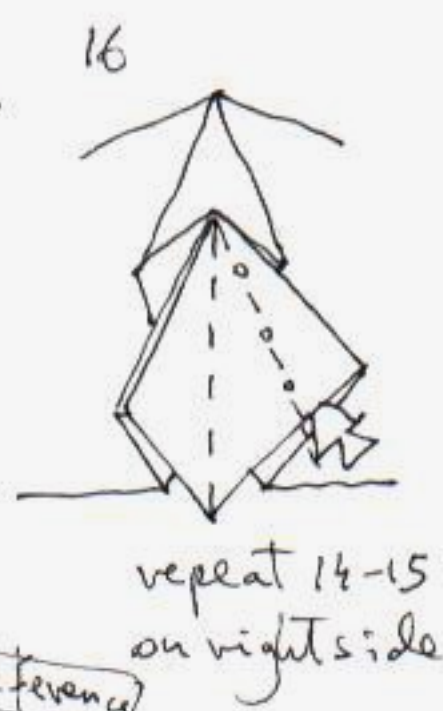
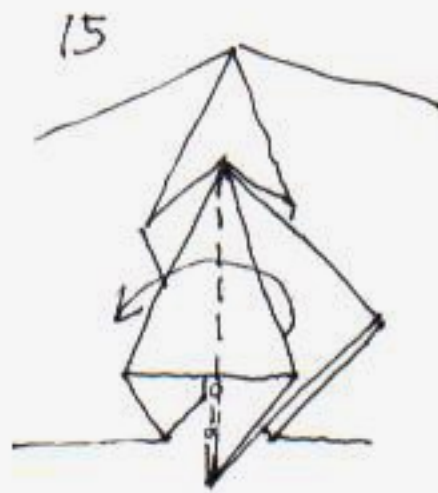

Ciervo

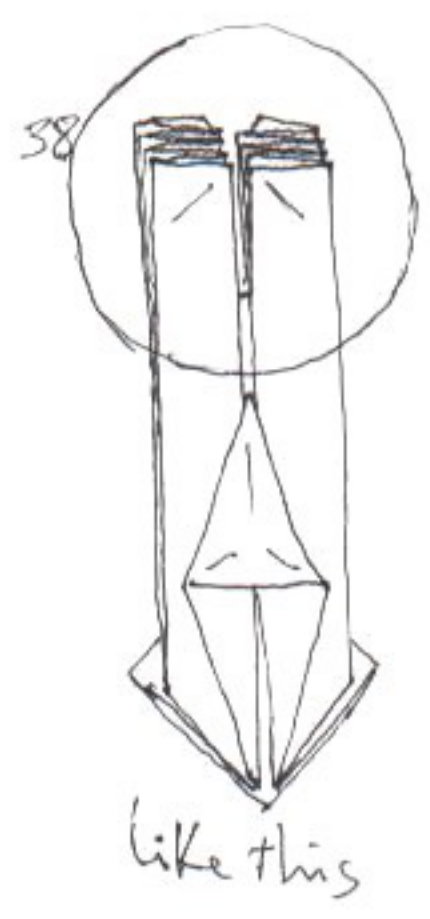
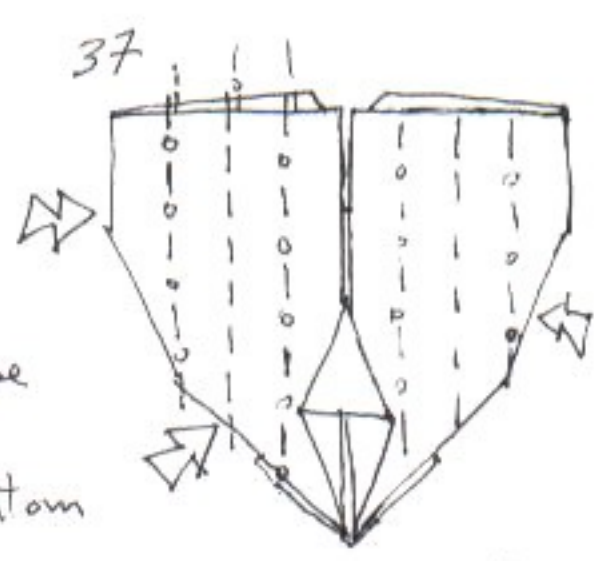
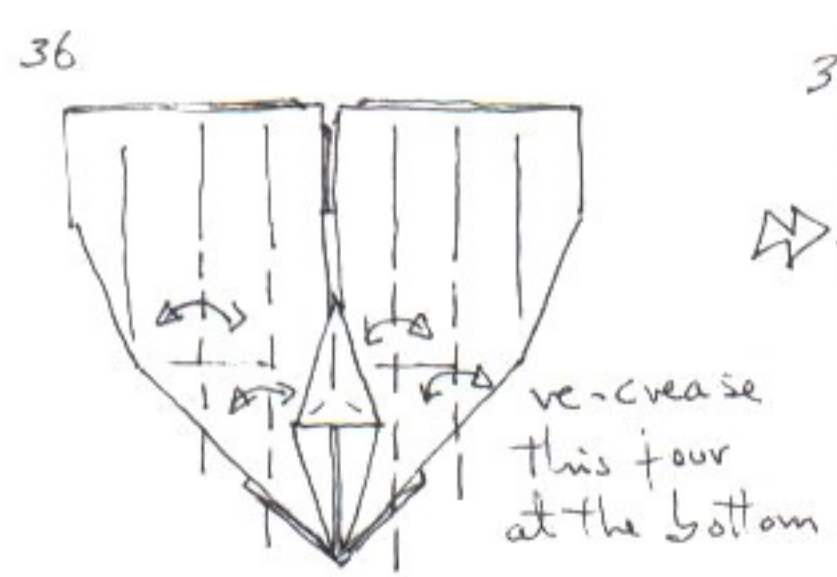
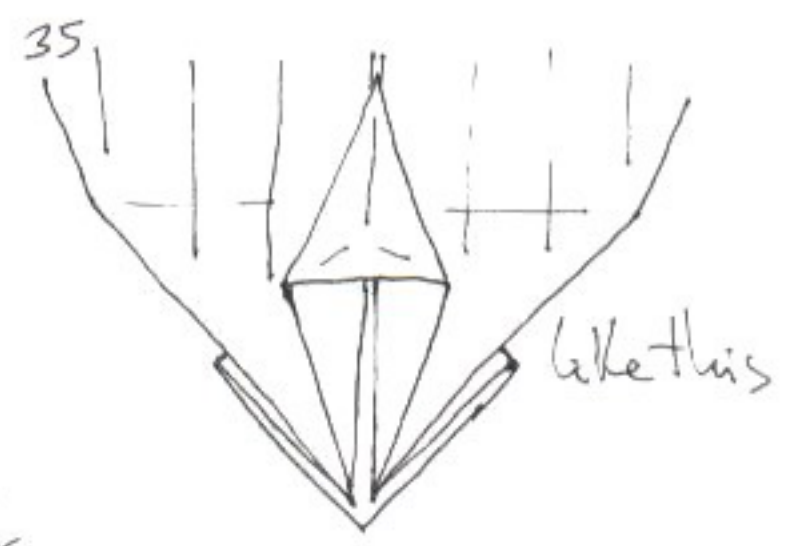
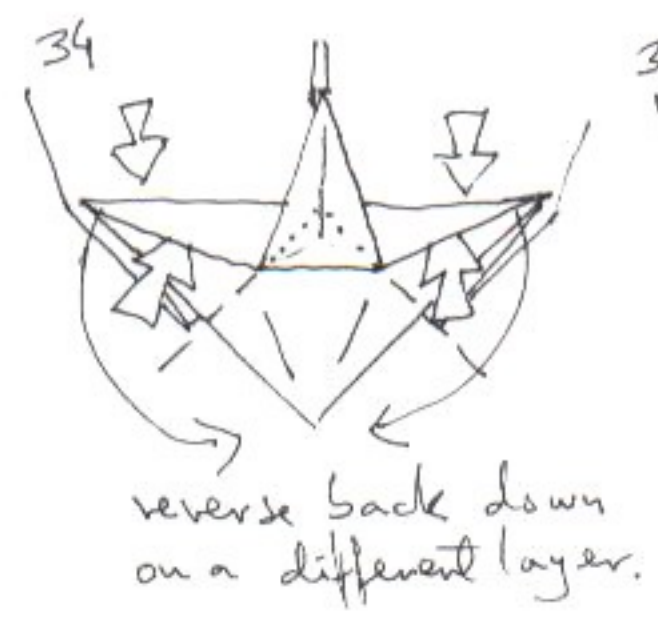
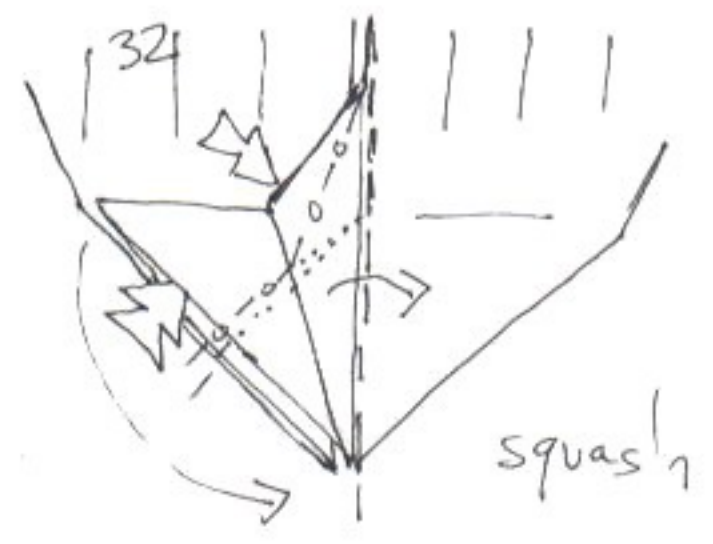
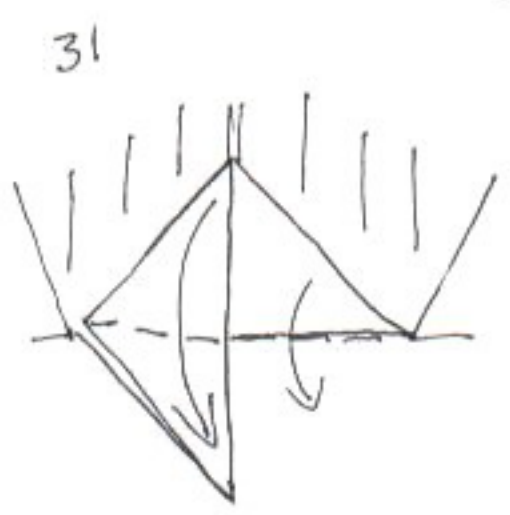
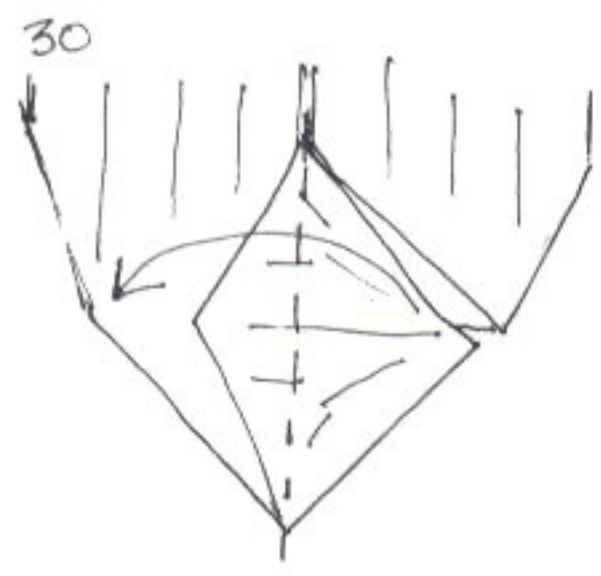
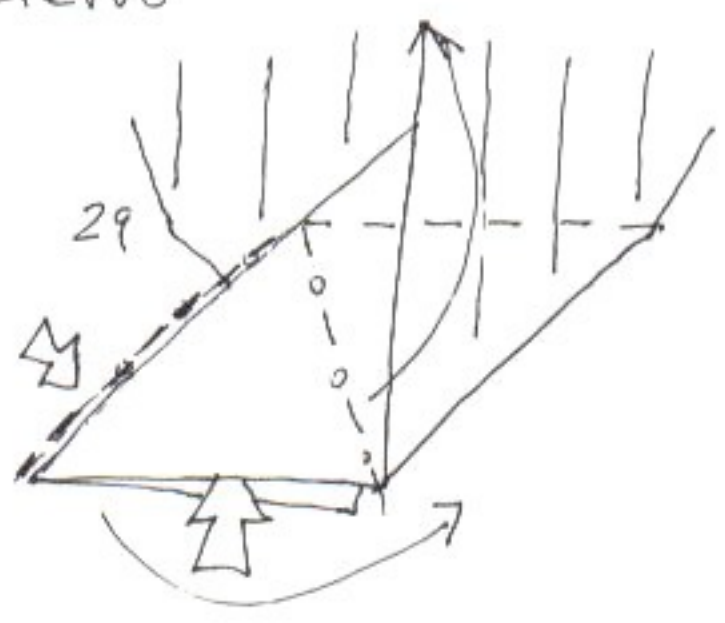
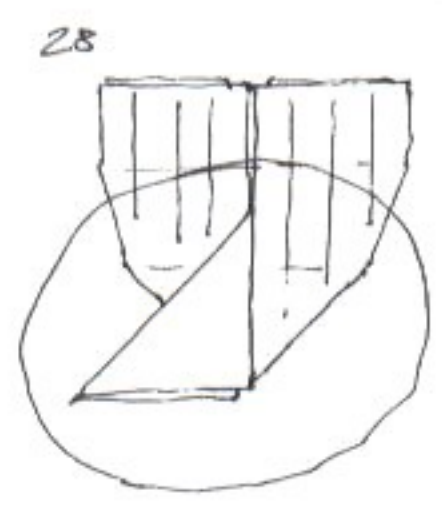
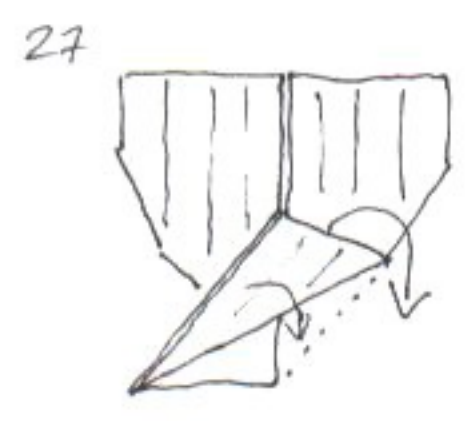

Ciervo

④

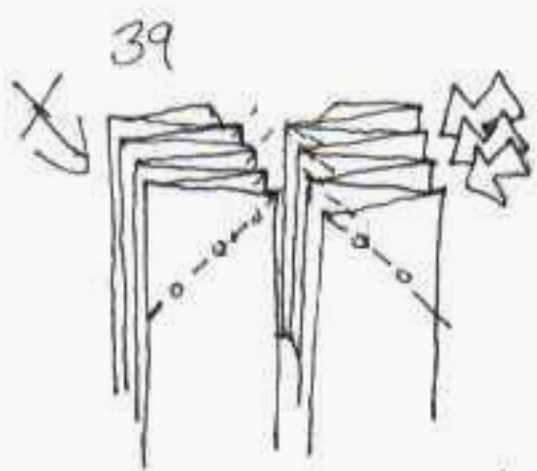

39
reverse fold 3 points
on each side.



40
Only the right side
is shown.
Pull nearest point
down while opening
the 2^o one.
Repeat on left side



41
pull down again while
opening the 3^o point.
Be very gentle, there
is an irregularity inside
that needs to be fixed
by small hidden creases
that form by themselves
as you flatten.
Repeat on the right side.

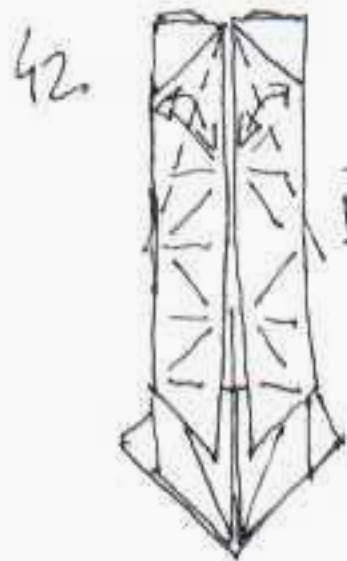

42
fold and unfold
both sides.

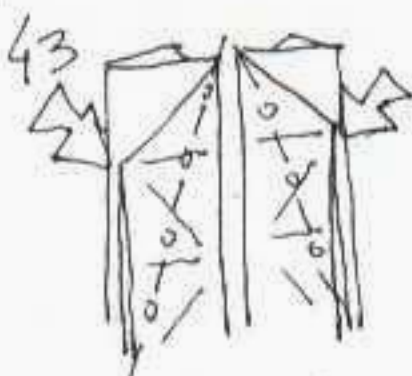

43
closed sink

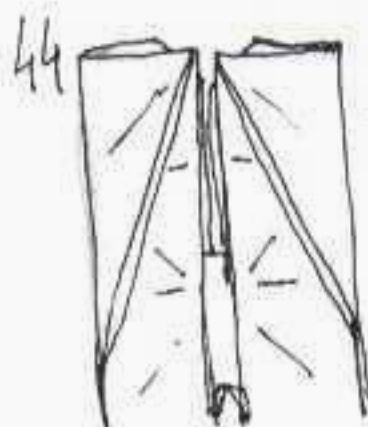

44
like this
turn over

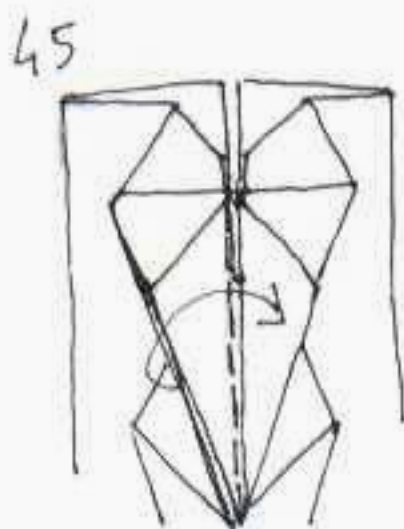

45
fold one flap over

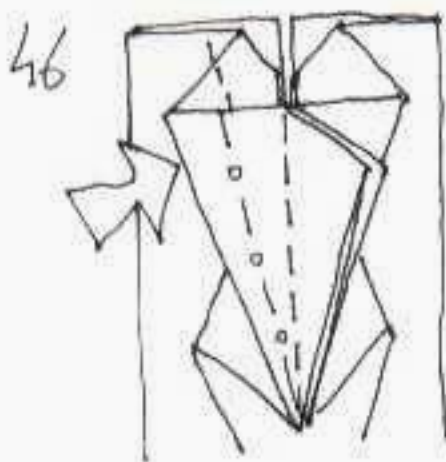

46
squash this
small flap



47
fold two flaps
back to the left

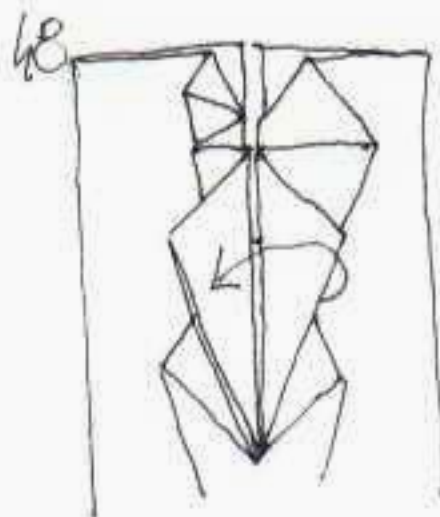

48
Repeat 45-47
on the right side

Ciervo

5



Like this
Only the left half
will be shown in the
next steps

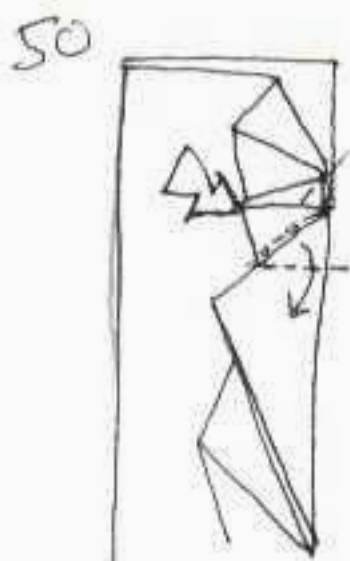

fold down
while reversing

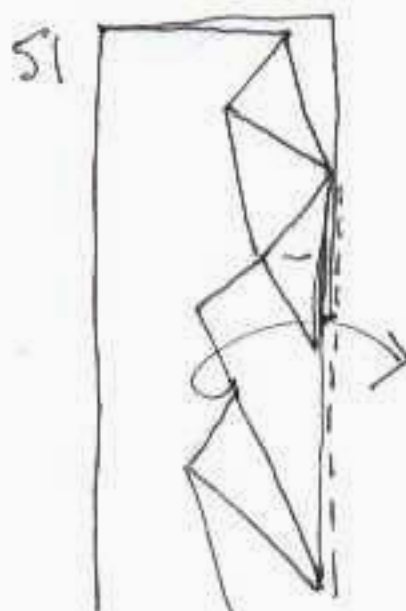

valley
flap



crease these two
lines through all layers
"a" runs over the layers
beneath and "b" is $\frac{1}{2}$ "a"

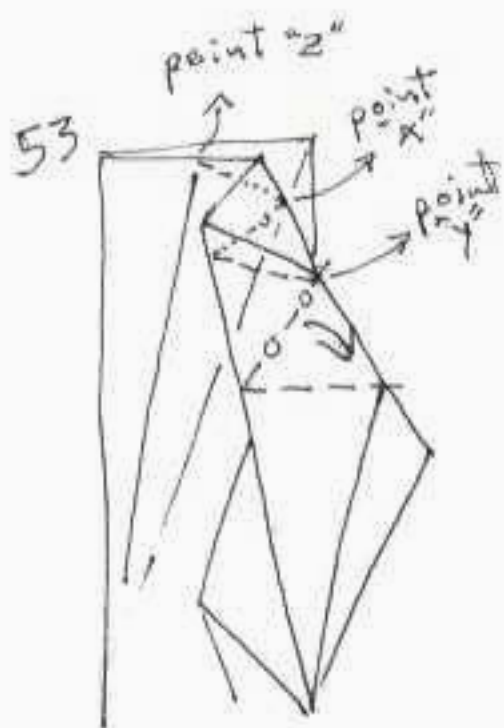

lift a bit point "y"
stretching paper
between "y" and "z".
It won't be flat.

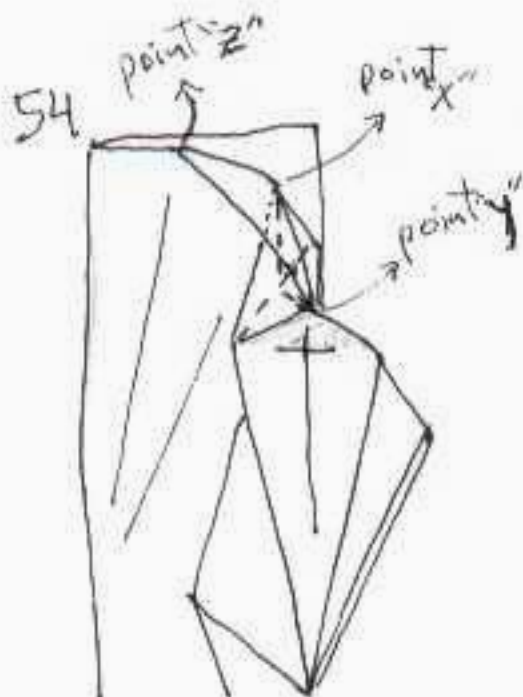

flatten "y" up,
reversing where
shown.



fold this flap
back to place.



reverse fold
in and out
symmetrically
throw crease
lines of step
52.

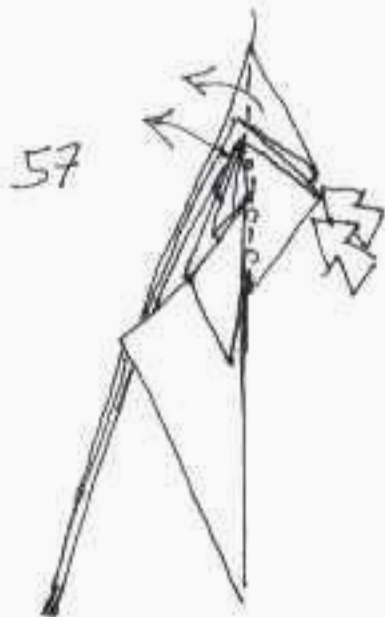

make two
reverse folds...
Remember only half
the head is seen
shown



... and two
more to complete
the horns; don't be so happy
Now repeat 50-58 on right side



side
view
outline

head

Ciervo

59

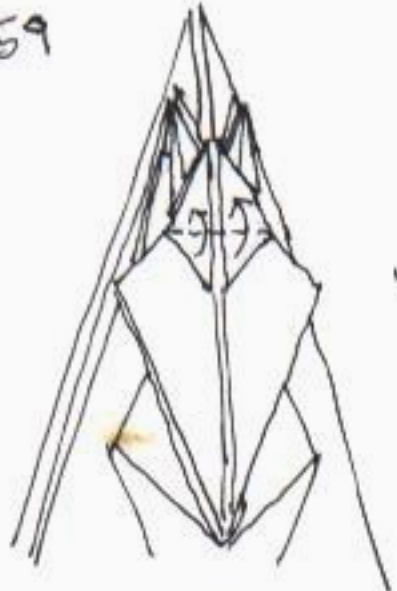

fold the two little flaps up. Turn over

60

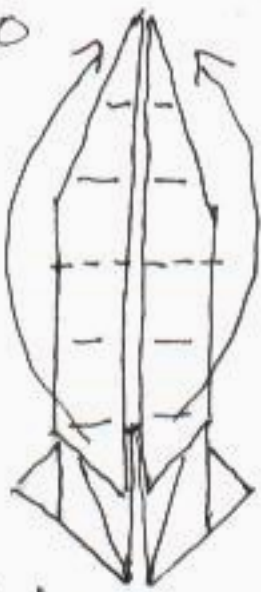

whole model down again. fold up the two long flaps.

61

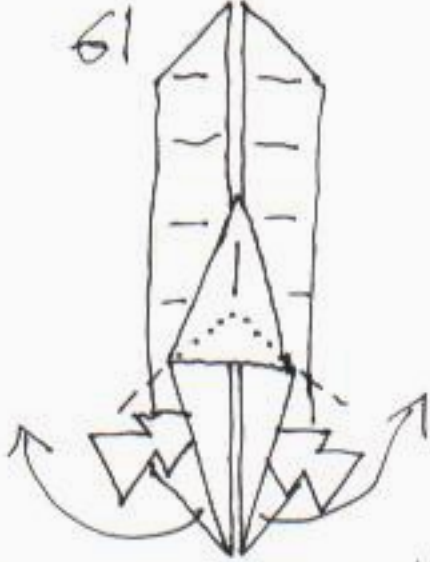

reverse fold both flaps to the sides

62

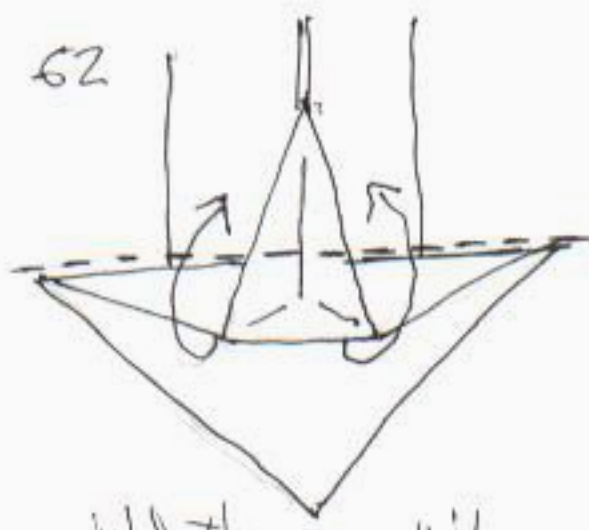

fold the small flap up.

63

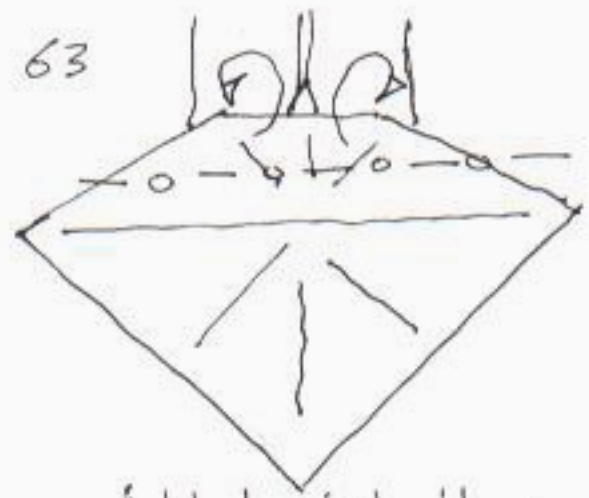

fold half the flap behind. Turn over

64

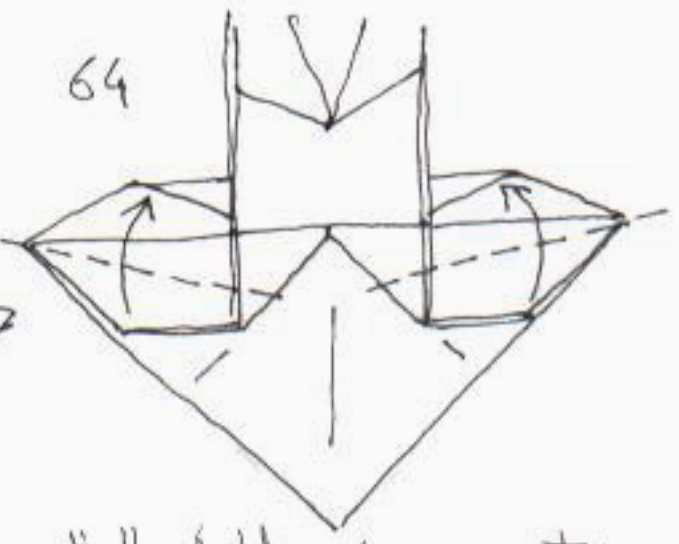

Valley fold. This is not in half. The corner just touches de border shown.

65

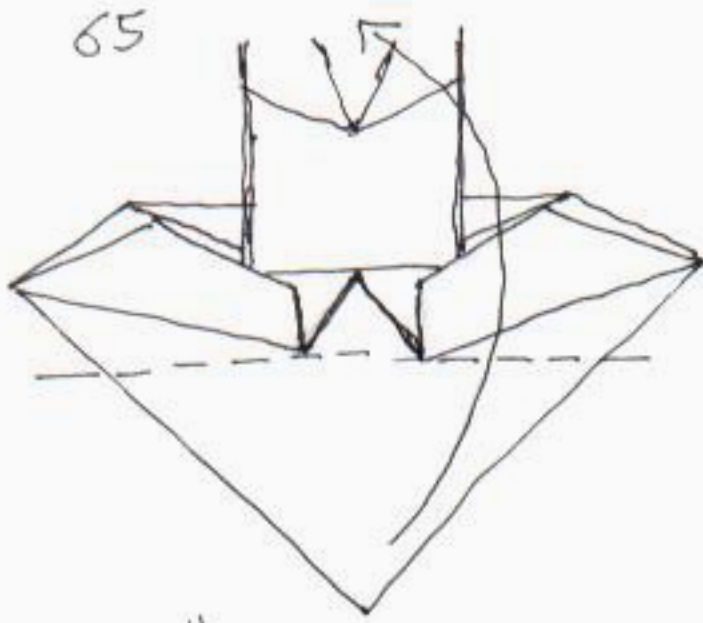

valley up

66



fold and unfold

67



valley down on the intersection shown.

68

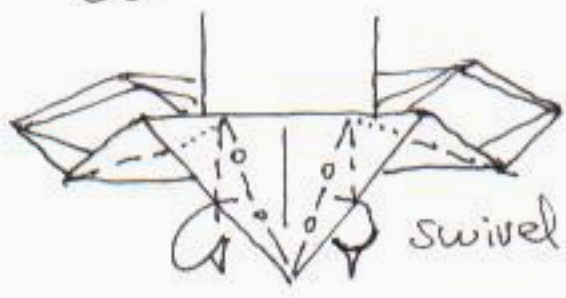

swivel in.

Cervo

69

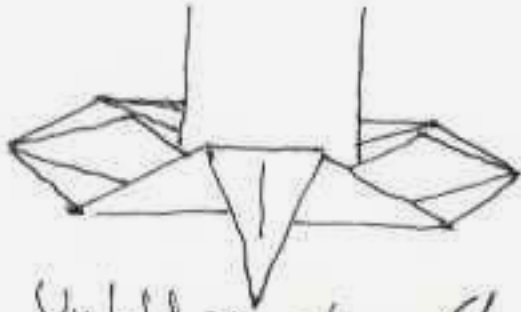

Unfold to step 64

70

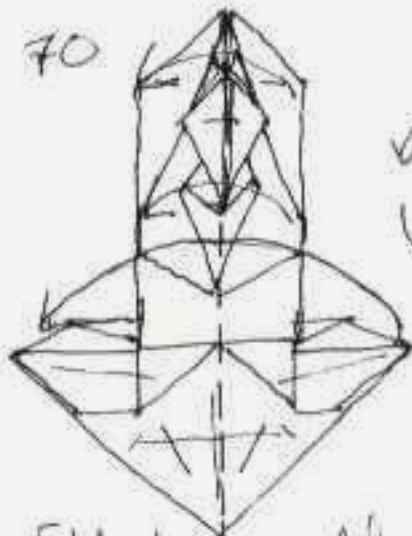

Fold whole model in half and rotate 1/4 turn.

71

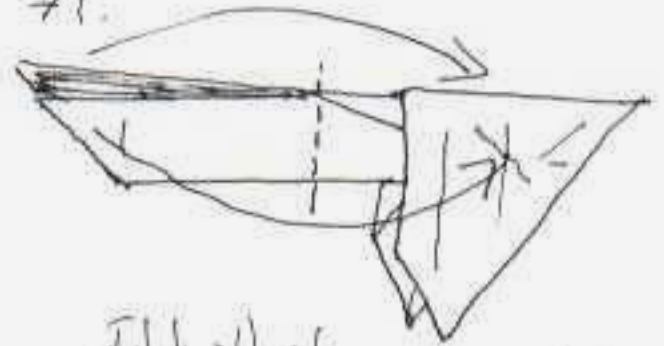

Fold the two long flaps to the right

72

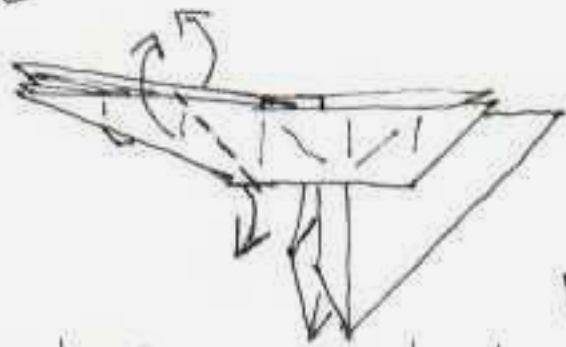

Outside reverse fold the whole ensemble allowing the point inside to stick down.

73

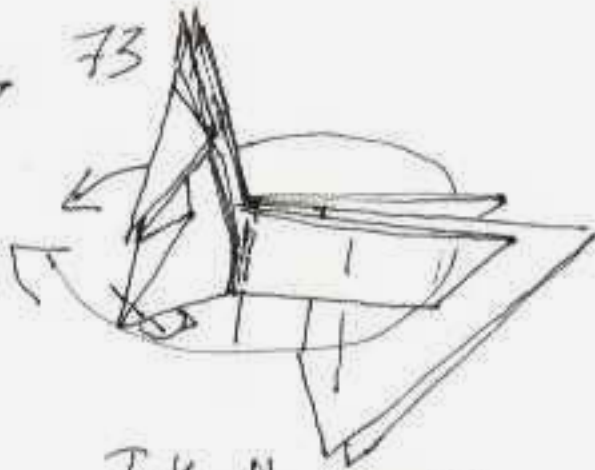

Take the long flaps back to the left. Fold the tip shown in.

74

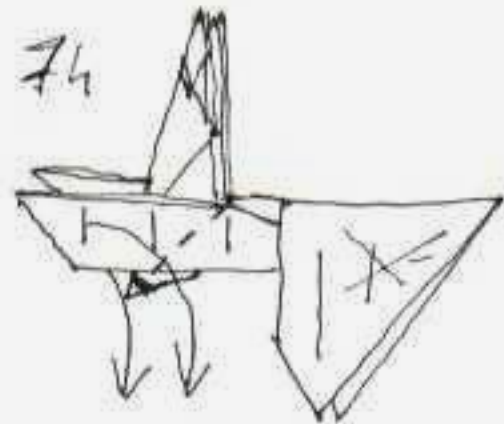

Valley fold the legs down.

75

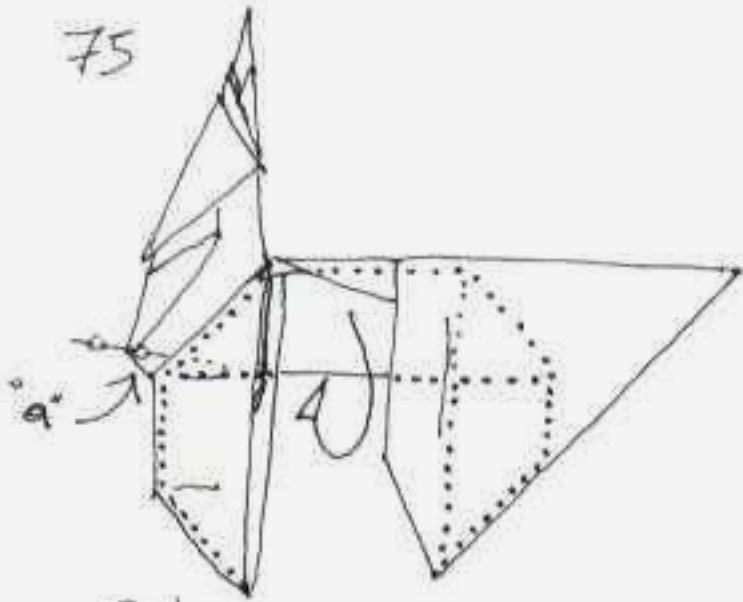

Pull out carefully the outer most single layer from the body and wrap it around the inside. A thin strip needs to be mountain folded at "a"

76

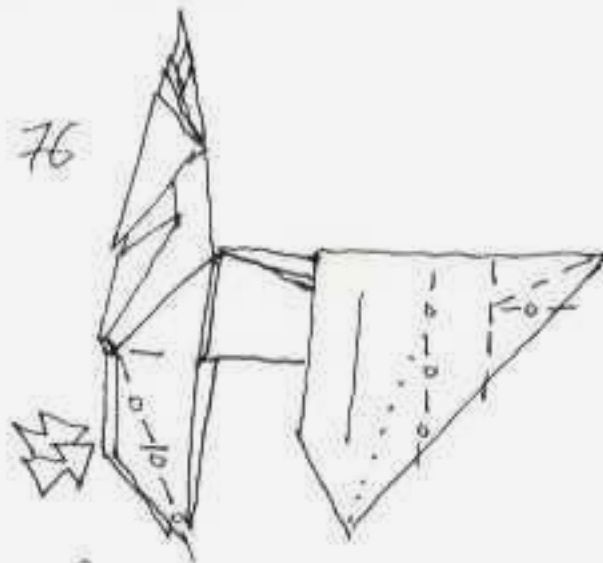

- Refold the hind legs (steps 64-68)
- Pre-crease and sink the fore legs. This is not in half.

This step is to prevent the limbs from opening out from the body. Repeat behind.

Ciervo

77

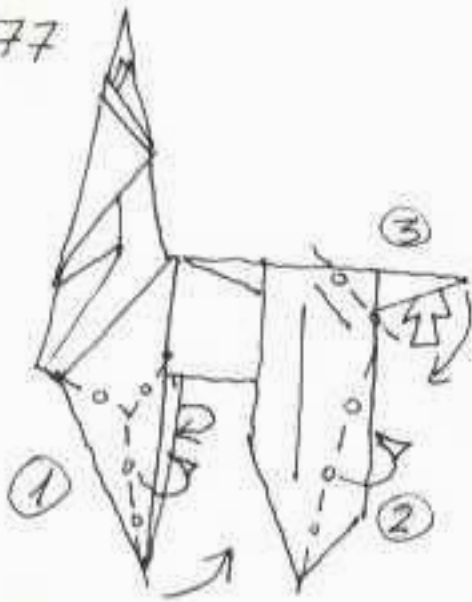

- ① double rabbit ear.
 - ② reverse fold behind the thick layers.
 - ③ reverse fold tail.
- Repeat ① ② behind.

78

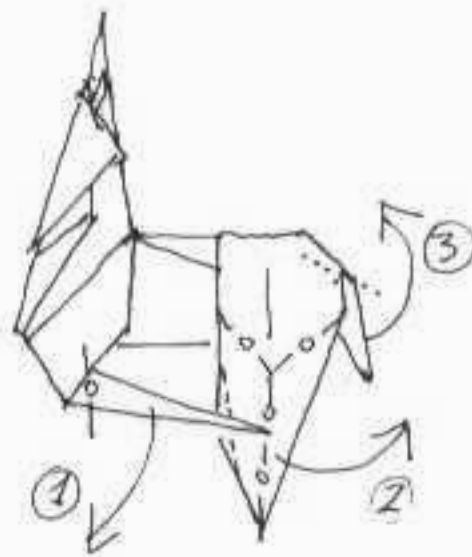

- ① reverse fold.
 - ② double rabbit ear.
 - ③ reverse tail up.
- Repeat ① and ② behind.

79

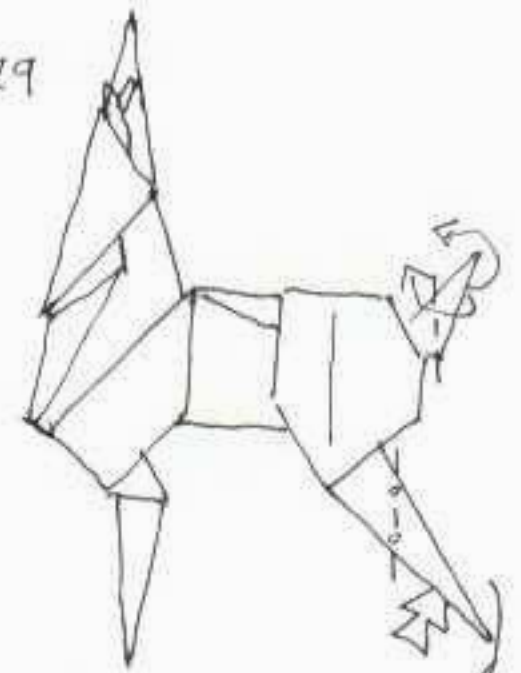

- Outside reverse fold the tail
- Reverse fold the hind legs.

80 Head



outside reverse fold.

81

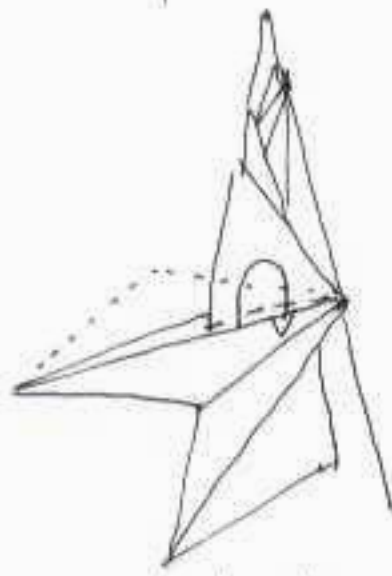

pull out some paper and refold it Repeat behind

82

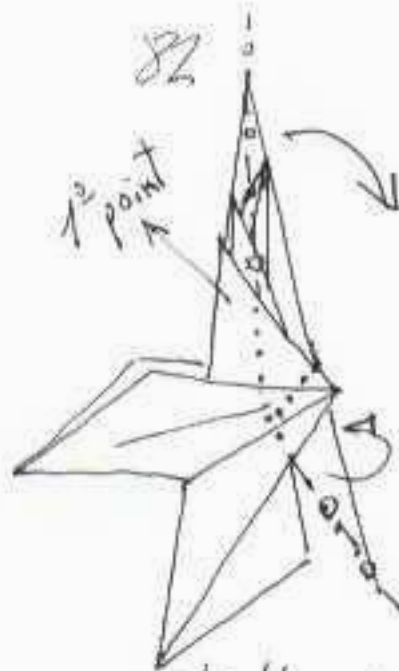

Take the horns ensemble except for the first point, and perform an incomplete rabbit ear. Do not flatten

(Only the right side horns are being shown)

83

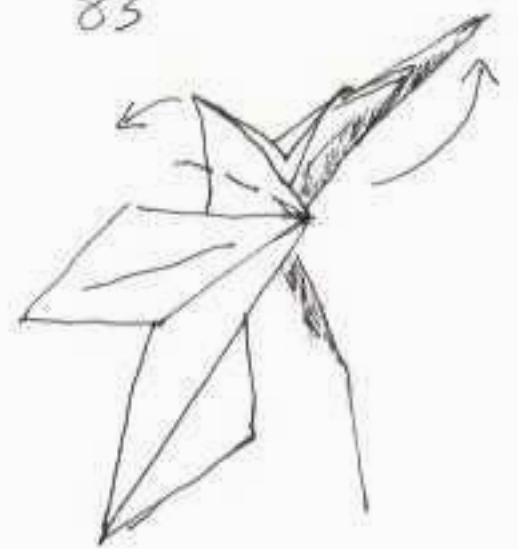

Soft shape it pulling towards you and curving up.

Ciervo

84



pull up three points
and curve to taste

85



Lift up a bit
these two layers
to form an ear

86



Like this.
Turn over and
repeat 82-86

87

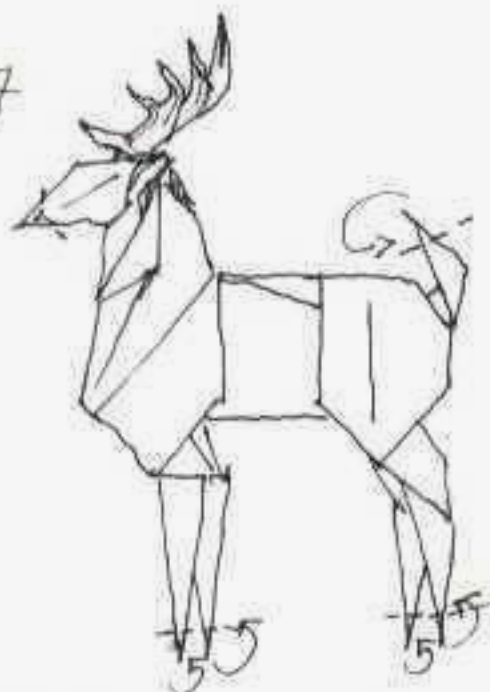

- reverse fold in strips
- make a very small
double-pointed ear in the snout.

88



- crimp to form hooves
- round top of body
- flatten the top of the head
- form a mouth.

89

finished
deer.



Román Díaz
5/03