

— IL Merlo —  
 (A. GiunTA 1987)  
 usare un foglio di carta  
 Giallo da un lato e nero  
 dall'altro

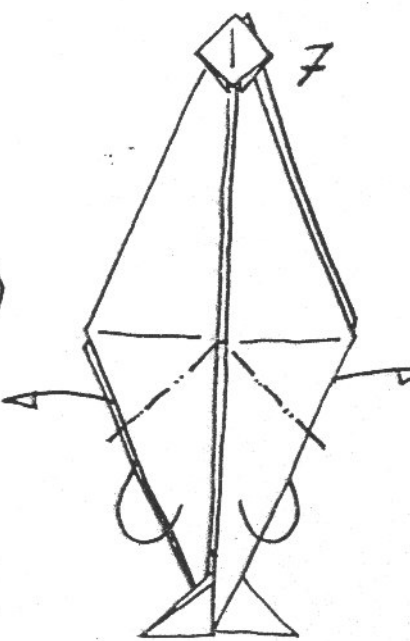

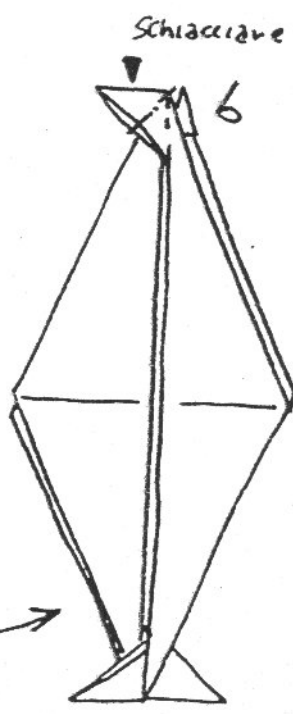

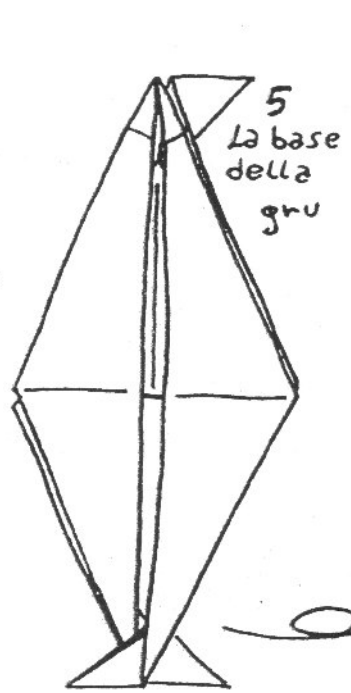
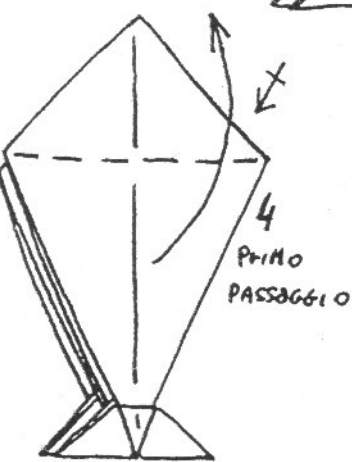
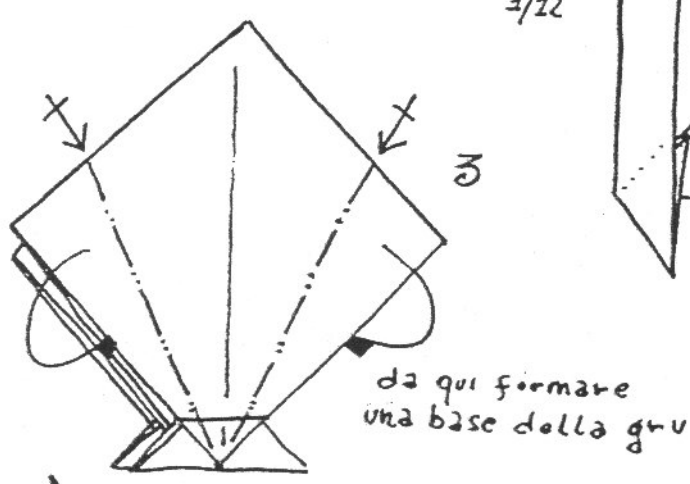
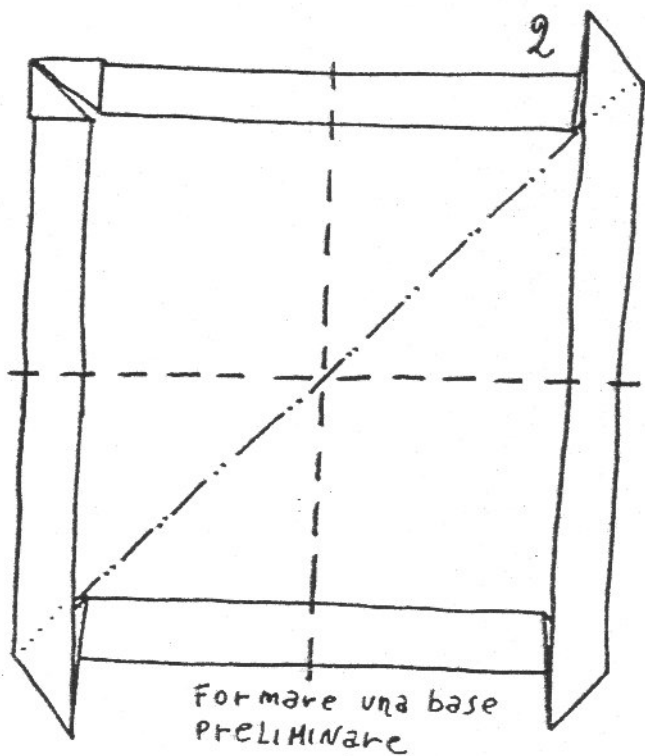
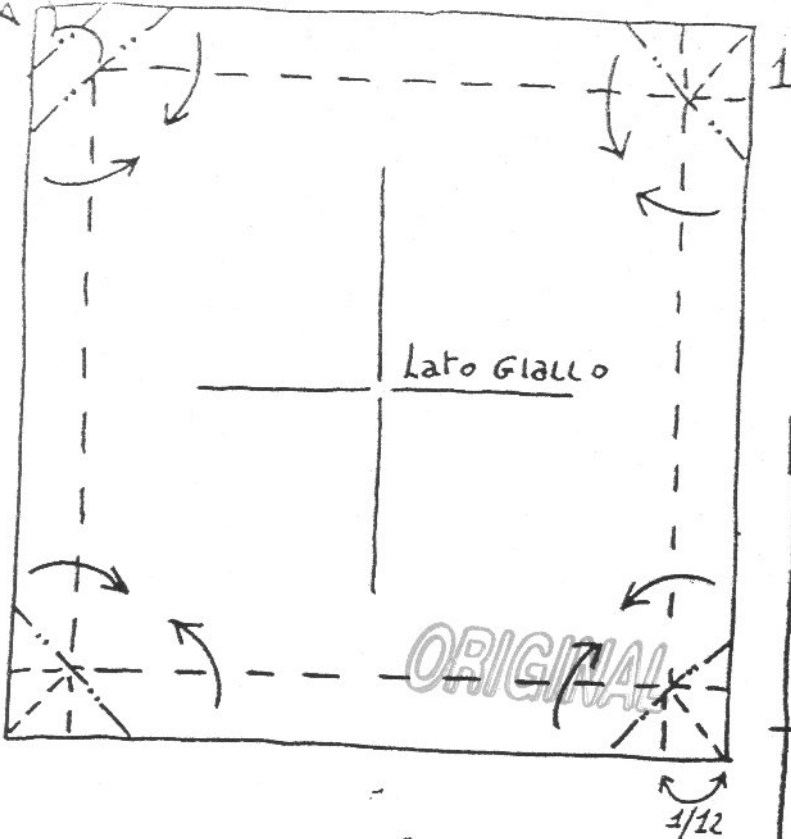
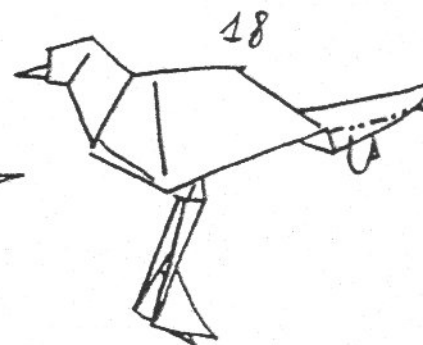
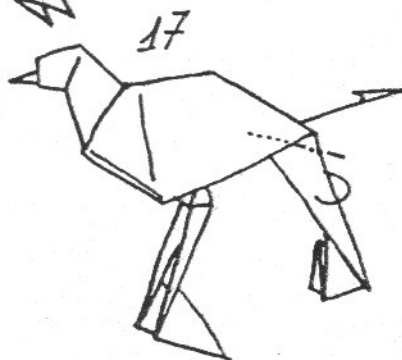
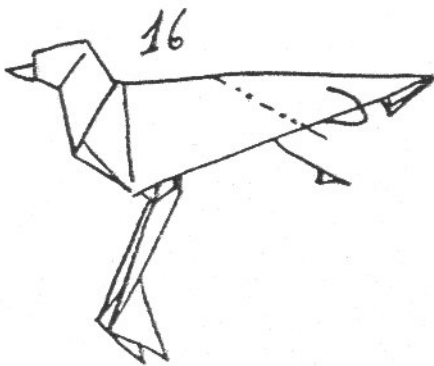
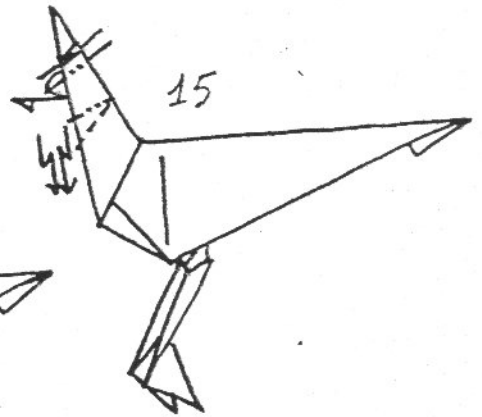
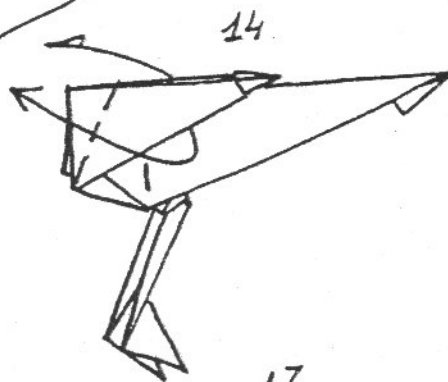
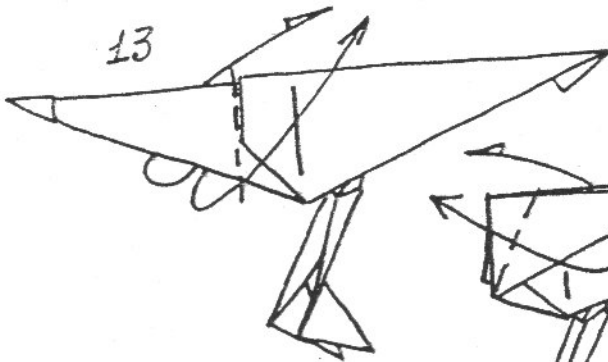
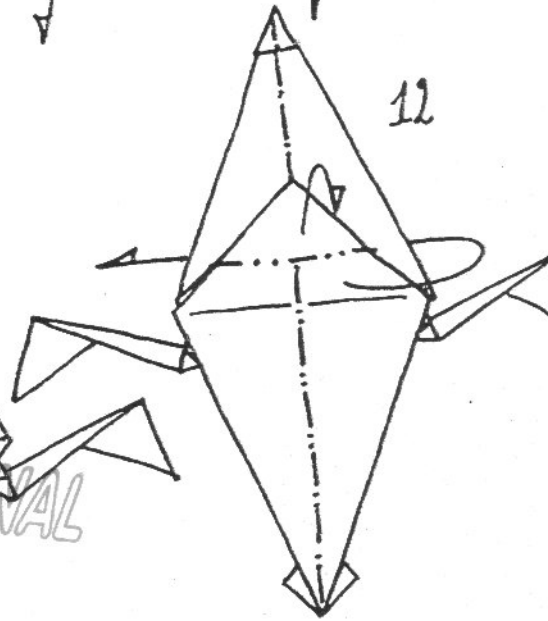
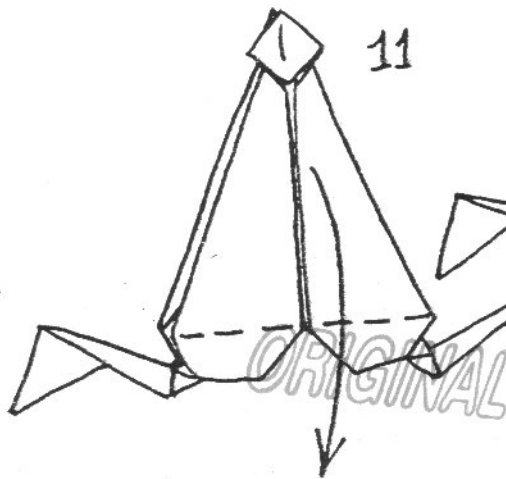
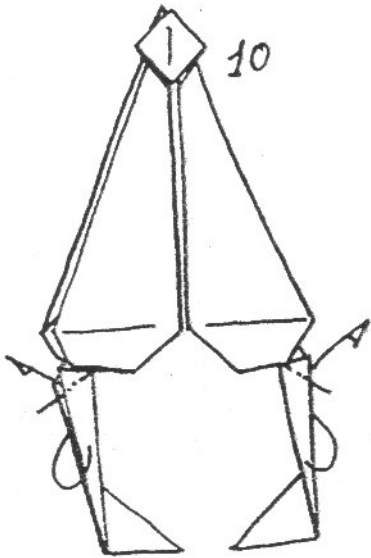
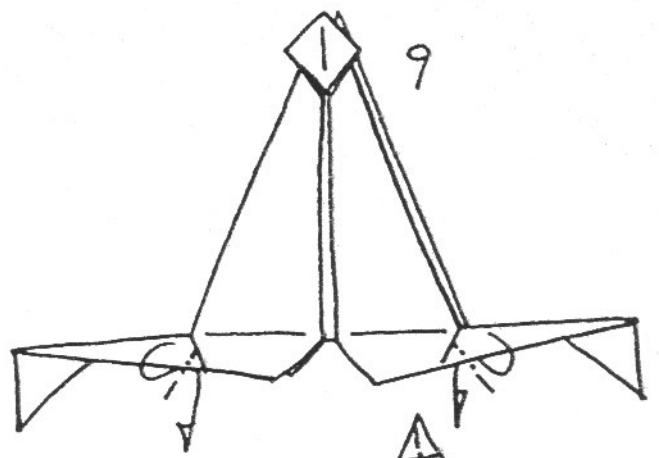
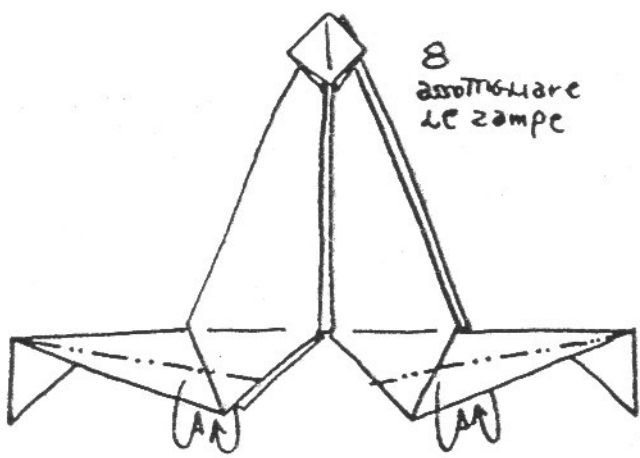
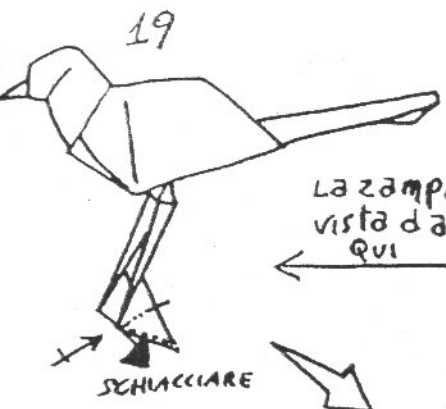

La zampa  
vista da  
qui

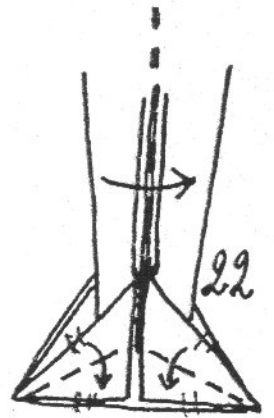
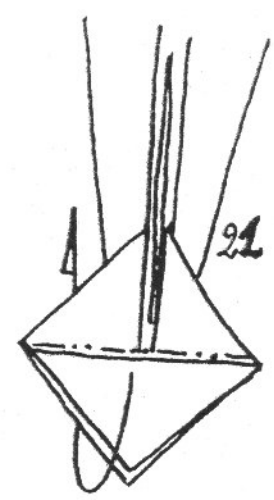
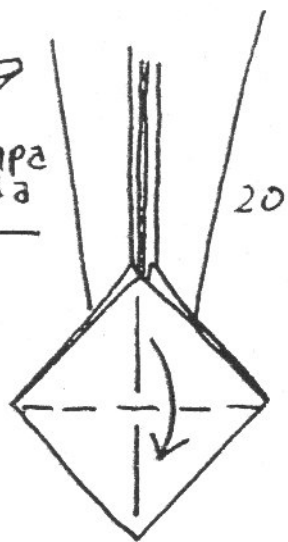

ORIGINAL

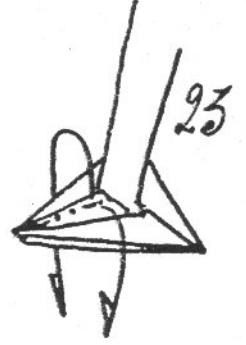
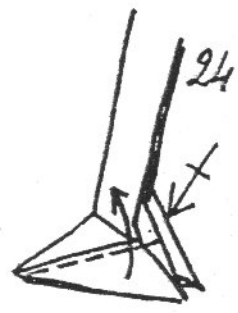
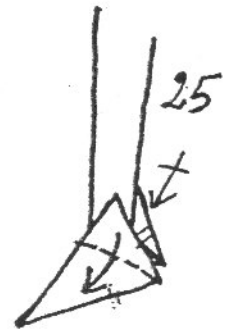
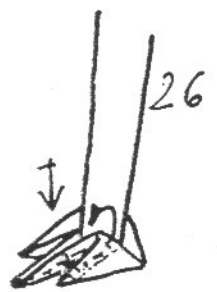

PER CHI VOLESSE  
REALIZZARE IL IV°  
DITO, DEVE APRIRE  
LA ZAMPA E TIRARE  
VERSO DESTRA L'ULTIMO  
LENBO DAL BASSO, POI  
RICHIUDERE ACCURATAMENTE  
ED ELABORARE LE PIEGHE  
PER FORMARE IL DITO.

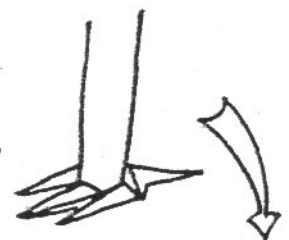

PIEGHE ARROTONDANTI  
PER DARE TRIDIMENSIONALITÀ

